

Series  
**AOE**



Air heating units with electric heaters for air heating of various premises

**Advantages of air heating:**

- ▶ quick temperature increase in the room up to set point;
- ▶ low inertia of the system allows to provide alternating heating mode or heating in some zones;
- ▶ high heating efficiency;
- ▶ capital investments for air heating system is much less as compared to the similar water heating system.

■ **Application**

Designed for air heating in the room with electric heater and air uniform distribution due to an integrated fan and louvre shutters. The air heating units enable quick air heating of large premises or provide local heating of a work zone, for example, in big airplane shed or production facilities.

The air heating units are designed for installation in manufacturing workshops, garages, car showrooms, stock houses, trade facilities, super- and hypermarkets, shops, sport halls, conference halls, poultry and cattle farms, greenhouses and other similar premises.

The unit design enables quick and easy mounting and its operation reduces total investment costs for heating system.

■ **Design**

The AOE unit consists of an axial fan and an electric heater enclosed into a steel polymer coated casing. The electric heater is equipped with two overheating thermostats:

- ▶ the main overheating protection with

automatic reset is activated at +50 °C. After the heater cooling the thermostat closes the heater control circuit.

- ▶ the alarm overheating protection with manual reset is activated at +90 °C. In case of alarm thermostat activation power supply to the heater is possible after manual alarm reset only.

■ **Fan motor**

AC motors with external rotor and built-in thermal overheating protection with automatic reset.

■ **Control and regulation**

For safe and correct operation the air heating unit must be controlled with integral control and protection automatic control system to provide the following functions:

- ▶ automatic power and heating temperature adjustment;
- ▶ power supply cut-off to the heater in case of the fan shutdown, low air flow or if integrated motor overheating thermostats are activated;
- ▶ air supply to the electric heating elements

for heating removal after shutoff of the heating unit;

- ▶ power supply to the heater via an integrated automatic circuit breaker with tripping current depending on the heater power.

The heating unit operation modes are controlled from UET-15D or UET-30D (available upon separate order) control unit.



Air flow temperature is controlled by the heater on/off switch time (full heating power) in compliance with a set heating point. The control unit controls the fan speed and cuts off power supply to the heater in case of the fan shutdown or very low air flow.

The control unit is designed for joint operation with digital TST-1-300 thermostats with sensor display

**Designation key:**

Series	Rated power [kW]
<b>VENTS AOE</b>	9; 12; 15; 18; 24; 30



**Accessories**

(TSTD-1-300 model is equipped with a remote controller) or RTS-1-400 with LCD display (RTSD-1-400 is equipped with a remote controller). The thermostats are available on separate order. The thermostat is designed for indoor installation in the room heated by the air heating unit to determine

its operation mode. The thermostat installation place must not be influenced by windows, doors and heating radiators. One thermostat is capable to control several connected air heating units in one room (max. 10 AOE units per each thermostat).

**■ Mounting**

The air heating unit is suitable for vertical installation on the walls (beams) or horizontal installation on the ceiling (beams).

**Technical data:**

	AOE 9	AOE 12	AOE 15	AOE 18	AOE 24	AOE 30
Voltage [V / 50 Hz]	3~ 400				3~ 400	
Fan power [W]	140				253	
Fan current [A]	0.61				1.1	
Electric heater power [kW]	9	12	15	18	24	30
Electric heater current [A]	13.0	17.3	21.7	26.0	34.6	43.3
Total unit power [kW]	9.14	12.14	15.14	18.25	24.25	30.25
Total unit current [A]	13.6	17.9	22.3	27.1	35.7	44.4
Air flow [m³/h]	2300				4000	
Rotation speed [rpm]	1420				1480	
Casing material	polymer-coated steel					
Sound power level at 3 m distance [dBA]	55				61	
Ingress Protection	IP 21				IP 21	
Weight [kg]	32				48	

**Overall dimensions:**

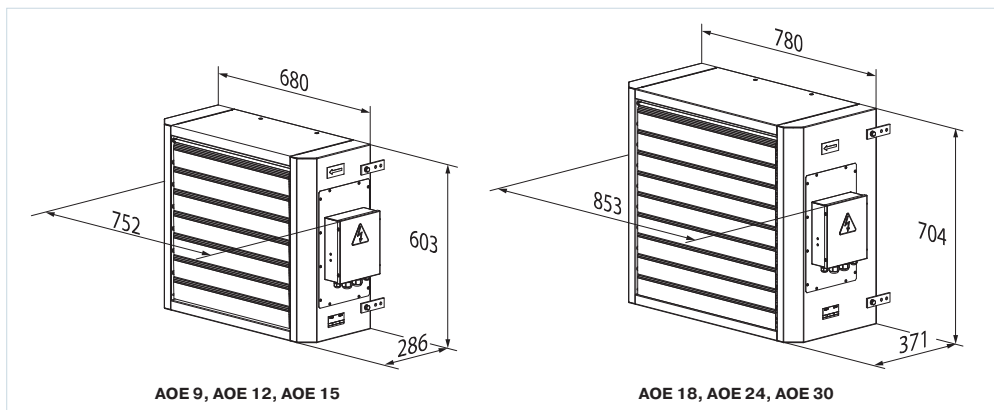

**Accessory selection table:**

Air heating unit model	Control unit	Digital thermostat		Mounting accessories		
		with sensor display	with LCD display	Mounting angles	Mounting brackets	Multi-angle bracket
AOE 9	UET-15Д					
AOE 12		TST-1-300	RTS-1-400			
AOE 15		TSTD-1-300	RTSD-1-400			
AOE 18	UET-30Д			MKP-AOW	MK-AOW 45	MKU-AOW 45
AOE 24						
AOE 30						

AOE AIR HEATING UNITS

### AOW AND AOE UNIT MOUNTING ACCESSORIES

We offer the following mounting accessories to make the unit installation easy and quick:

✓ mounting angles ✓ mounting brackets ✓ multi-angle bracket

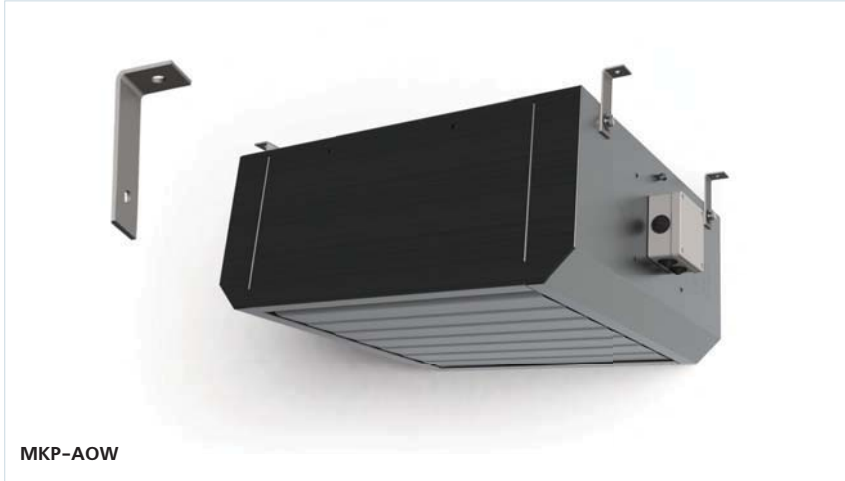

1. The angles are used for horizontal attachment of the unit to the ceiling with mounting studs or chains. This mounting option is applied only for the units operating in heating mode.



2. The mounting brackets enable vertical attachment of the unit to the wall or beam or horizontal fixing to the ceiling. This horizontal mounting is applied only for the units operating in heating mode.

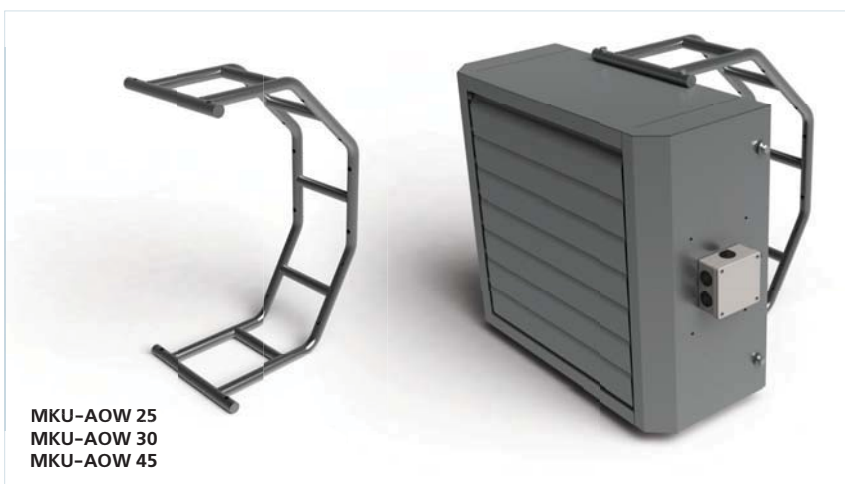

3. The multi-angle bracket enables attachment of the unit to horizontal or vertical structures tilted at 45° or 30°.

#### **WARNING!**

While mounting AOW/AOE units provide free air supply to the fan suction vent by keeping the minimum distance from the units to the wall or ceiling 300 mm.

Warm air distribution

